

# Gene Anderson's Star of the Show

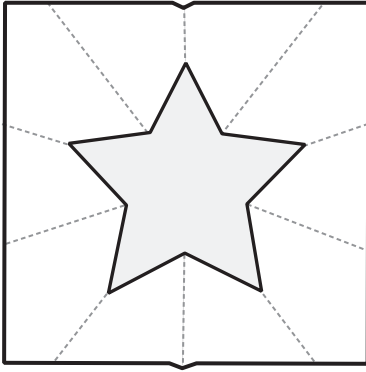

**Big Picture.** With folds and a single snip, you will cut a star-shaped hole in a newspaper and look through the star. The result in performance is surprising and humorous. It's a good show opener.

**Preparation.** That's the (almost) secret key to doing *entertaining* effects with newspaper. Audiences won't wonder how you cut a star; they'll wonder how you cut one so fast and so well. The stated answer to their unvoiced question is, "Advance preparation." That could be minutes, or months, in advance.

## A. The mighty template

Templates are great tools for repetitive tasks. A five-pointed star has ten folds, so  $360^\circ$  divided by  $10 = 36^\circ$ . That's the angle for the template. Having figured that out once, you don't want to think about that ever again. That's why you make a template. Got the idea?

Making a Star template with a  $36^\circ$  angle is easy. Draw an 8x11-inch rectangle. The corner-to-corner diagonal is a triangle with a  $36.03^\circ$  angle. That's close enough to make a great Star template (*fig. A3*).

1. Customize the Star template for your own newspaper's size. Sketch the triangle (*fig. A3*) on a piece of posterboard, or a cereal box.

2. The template needs to be half the height of the newspaper's page. Initially cut the template longer than needed (*fig. A4*), and then trim it to size.

3. Mark the Star template as shown in *fig. A5*, and draw a line connecting the points at the 4- and 8-inch marks. A matching line will be drawn on the folded newspaper (*fig. B6*), marking the Star for cutting during the performance.

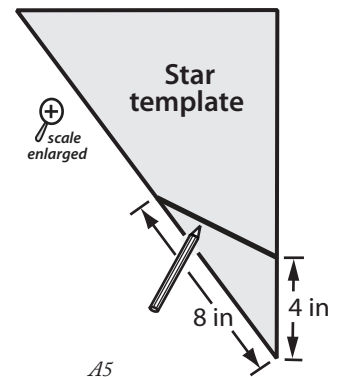
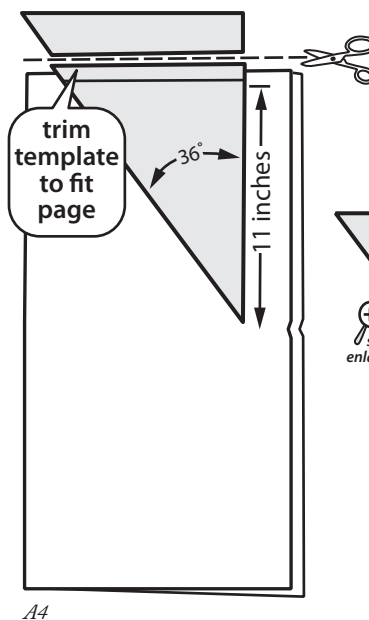
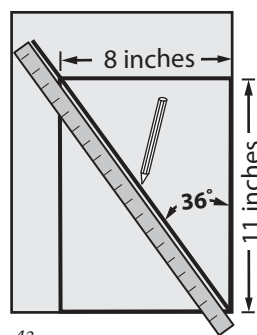
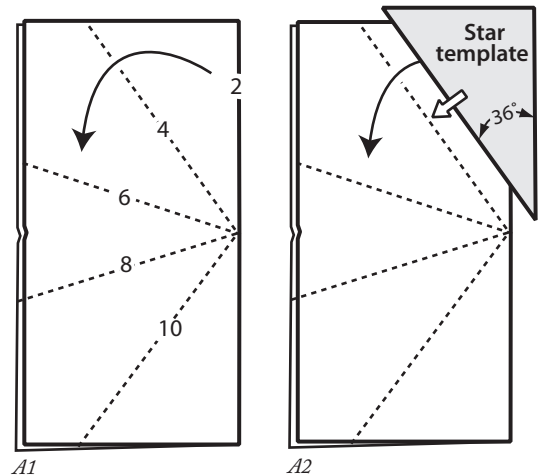

## B. Folding the star

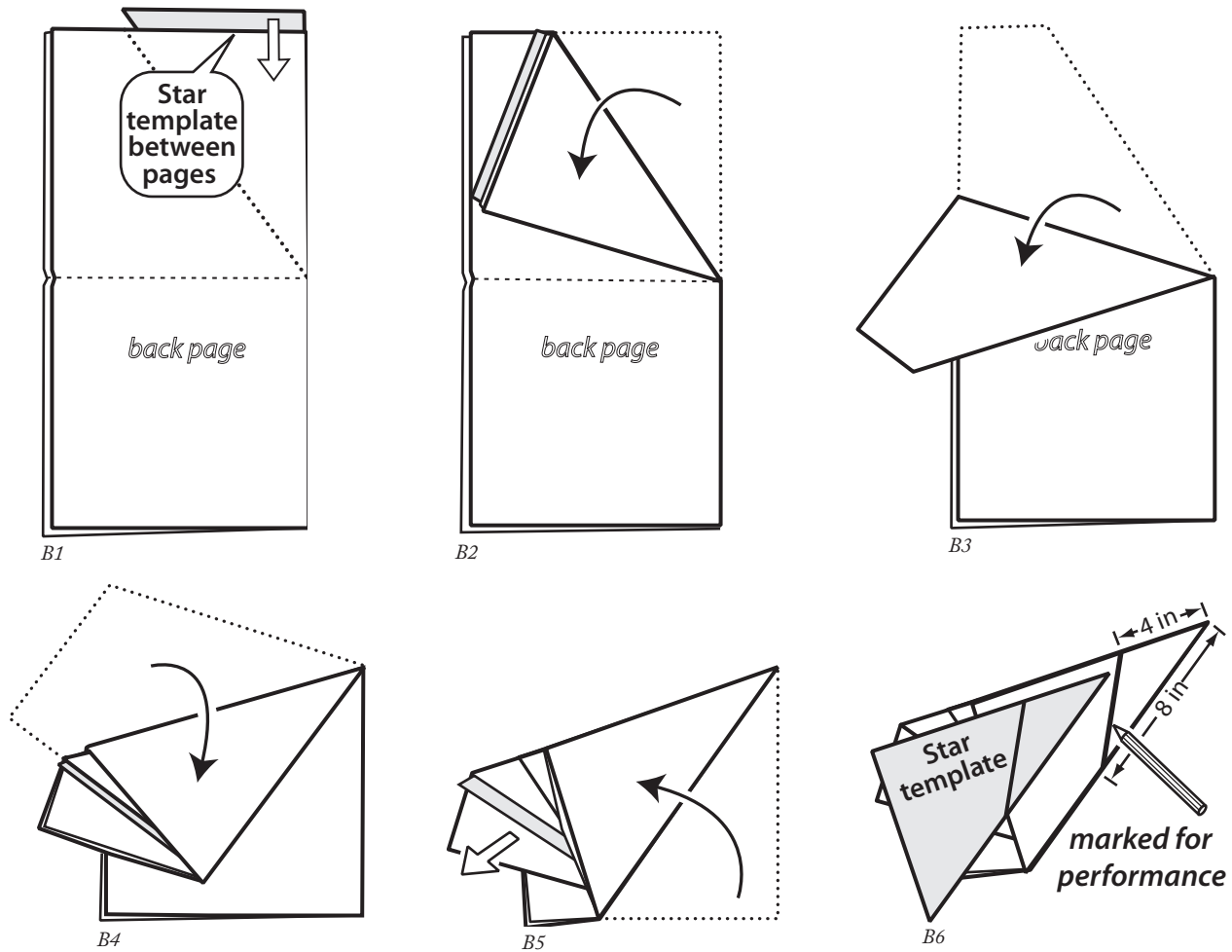

Fold and mark the newspaper as shown. Store the marked newspaper in *folded* position until shortly before the performance, and then *unfold it* so it looks like a “normal” newspaper. (It’s not a big deal if some people notice it’s been pre-creased.) In performance, the newspaper retains a memory of the creases, and it almost folds itself.

## C. Performance

Just fold, snip, and smile! In brief, fold the paper, cut on the line, look through the star-shaped hole with a big smile, and then announce, “The star of the show!”

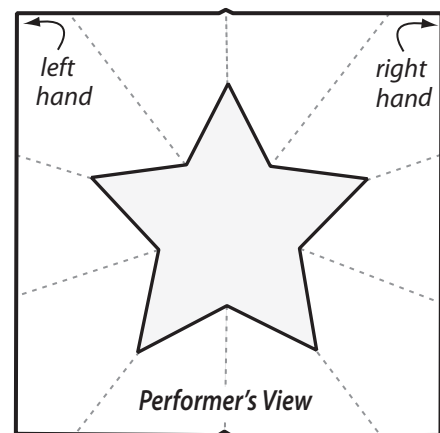
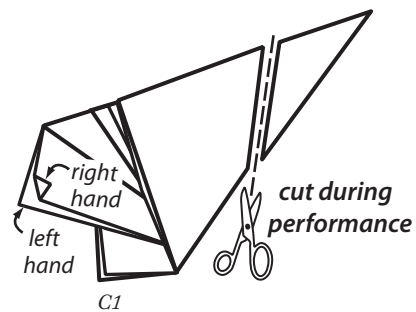

illustrations by Gene Anderson